

Cyclone ITM

VORTEX SETTLING CHAMBER

Owner's Manual

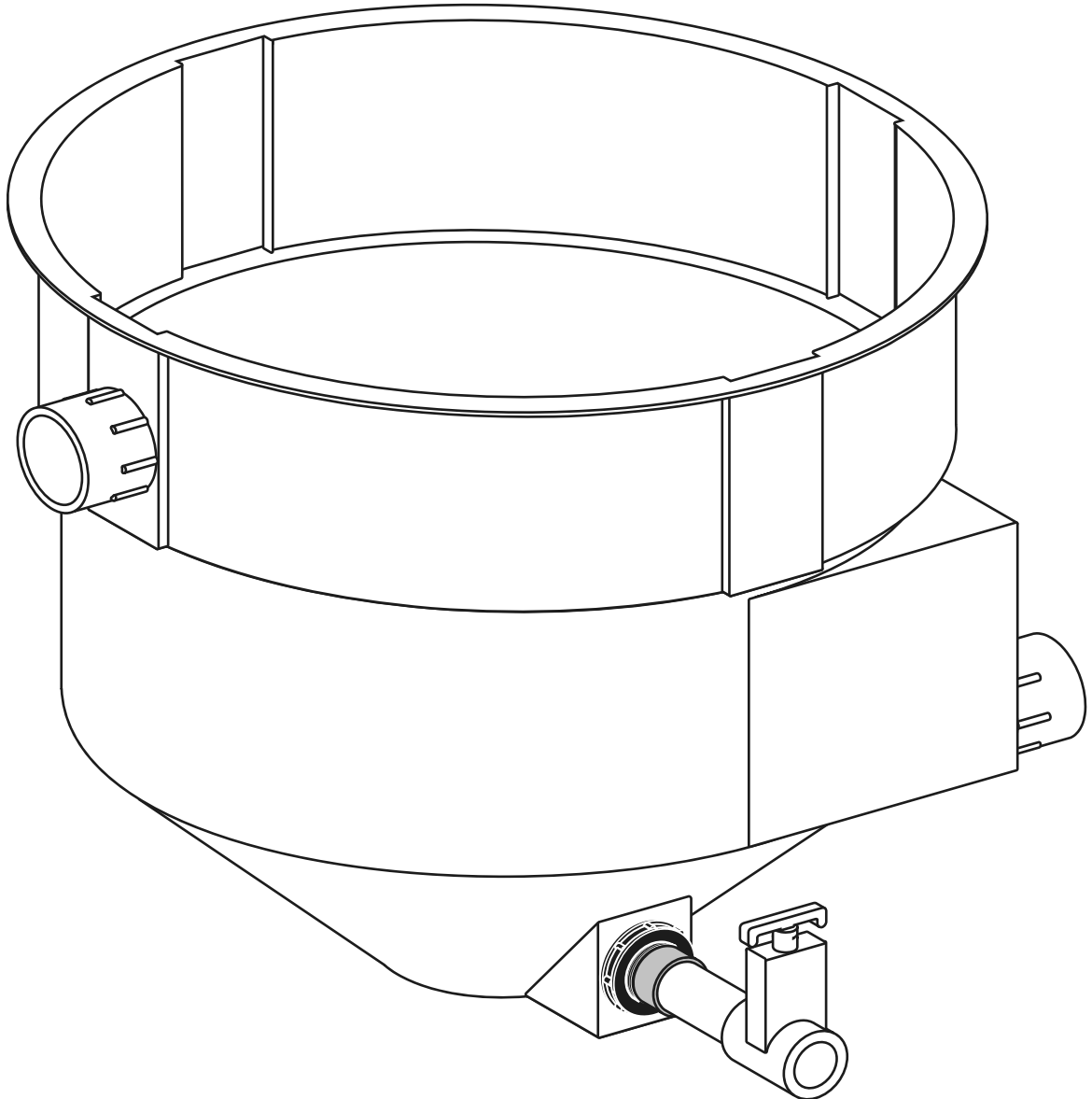

Patio Ponds LtdTM

Building America's Best Filters Since 1987

2909 Urbana Pike • Ijamsville, MD 21754

Introduction

Thank you for choosing a Cyclone I Vortex from Patio Ponds. This booklet will assist you in understanding the features of your settling chamber, as well as installation and maintenance. Let's get started by familiarizing ourselves with the components of the settling chamber.

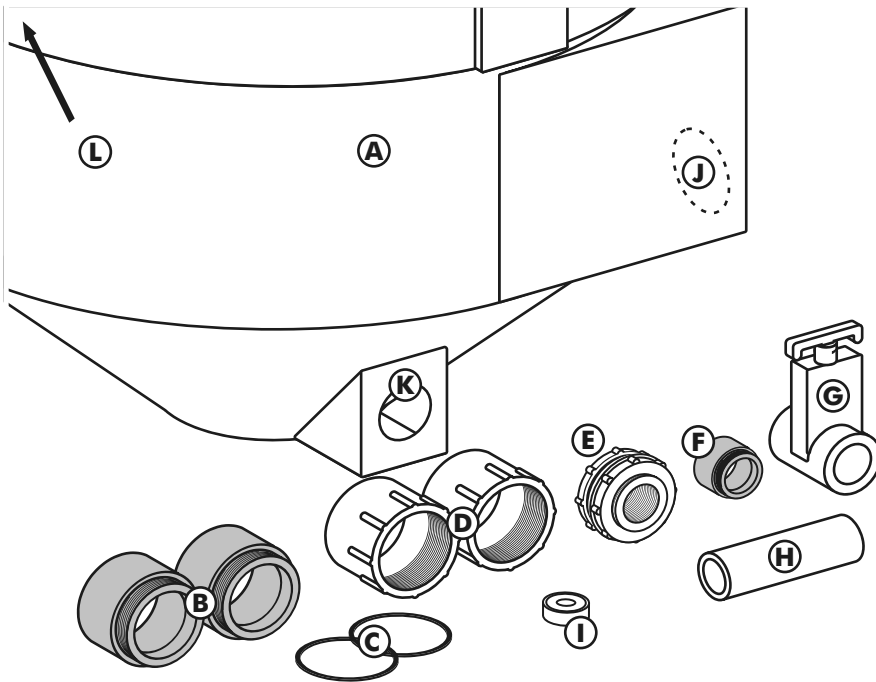

Parts & Features List

- A) Filter Body & Lid (not shown)
- B) Two 4" male adapters
- C) Two 4" O-rings
- D) Two 4" female adapters
- E) 2" bulkhead
- F) 2" male adapter
- G) 2" Drain Valve
- H) 2" PVC pipe
- I) Teflon thread tape
- J) Input
- K) Waste drain
- L) Output (not shown)

Locating Your Settling Chamber

Before you begin assembly, it's a good idea to find a permanent home for your Cyclone I Vortex. Start by finding an area close to the pond with easy access to your main filter. If possible, locate the settling chamber so the drain line from the Waste drain (K) can slope downhill.

Additionally, your settling chamber will need to be placed on a concrete base at a specific height in relation to your pond water level. This is necessary for gravity-fed operation, which requires the water level in the settling chamber and the pond to remain the same. For the Cyclone I Vortex, the base of the cone should be located 38" below pond water level.

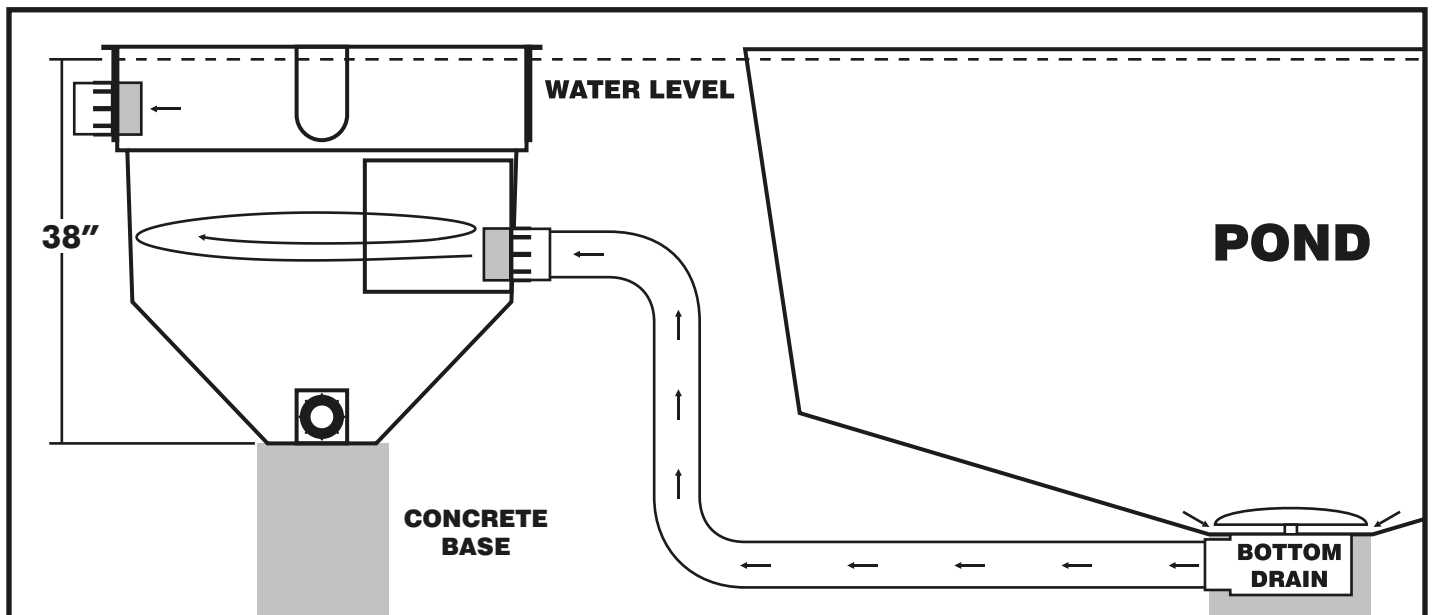

IMPORTANT!

Do not locate the settling chamber higher or lower than the recommended level. Failure to properly site the settling chamber will severely effect operation!

Additional Parts Needed

Unfortunately, we can't include everything you need to install your Cyclone I Vortex. You will need the following items from your local hardware store:

- PVC cement & primer
- 2" & 4" PVC pipe (length varies depending on application)
- 2" & 4" PVC elbows & connections (varies depending on application)
- Concrete pylon mold & concrete mix

You will also need these items from your local pond dealer:

- 4" Gate valve
- External pond pump rated between 3,000 to 4,000 GPH at the height of your filter

Assembly

Now the fun begins! If you feel uncomfortable performing any of the following steps, ask an experienced friend to help or hire an appropriate contractor to complete the work.

STEP 1: Prepare concrete base

Because the Cyclone I Vortex will weigh nearly 1,300 lbs. when filled, it is necessary to pour a concrete base to prevent settling. If you've installed a deck footer, you can install the concrete base for your settling chamber.

After you have chosen an area to place your settling chamber, use a hose level to mark the pond water level. Excavate down 38" from the mark until you have enough room for the settling chamber and plumbing. Always call your local utility companies before beginning excavation.

Excavate an additional 24" of soil and place a concrete pylon mold in the excavation. Measure 38" down from the pond water level and adjust the top of the mold to match. Level the mold and backfill, making sure to check your height and level periodically. After backfilling and leveling, pour well-mixed concrete into the mold. Stir and shake the concrete to remove any air pockets. Level the top of the concrete and allow it to set.

STEP 2: Construct plumbing from pond

The amount of water you will be able to pump out of your settling chamber is dependant on the plumbing between the pond and the chamber. Because the settling chamber is fed by gravity only, pipe friction can reduce your effective flow rate. Using the right diameter of pipe will ensure proper operation.

Distance from pond	Recommended Piping
Less than 15 feet	4" PVC
15-30 feet	Two 4" or one 6" PVC
30-50 feet	Two 6" PVC

After determining what pipe size to use, construct a feed line from your pond bottom drain to the settling chamber using PVC Pipe & Cement. Be sure to prime the fittings ahead of time, and follow all instructions and precautions given by the cement manufacturer. Make the line as simple as possible and avoid using hard 90° elbows – use two 45° elbows or one long-radius 90° elbow instead. Leave the end of the feed line unfinished until final chamber placement.

STEP 3: Wrap threaded fittings

Gather the threaded fittings (B) & (F). Using Teflon tape (I), wrap the threads of each fitting 3-4 times to prevent leakage.

Wrap the fittings like this →

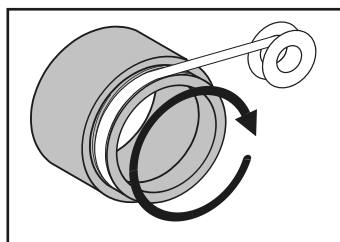

STEP 4: Install Input & Outlet Bulkheads

Take the 4" O-rings (C) and push them onto the 4" Male Adapters (B). Place the fittings on the inside of the Input (J) and Output (L). While holding the Male Adapter (B) in place, thread the 4" Female Adapter (D) over the exposed threads until snug. Hand-tighten only.

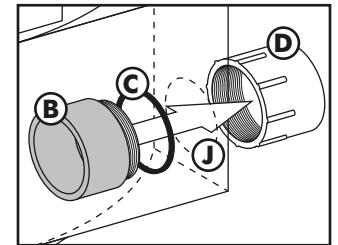
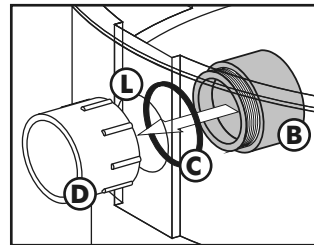

STEP 5: Install Drain

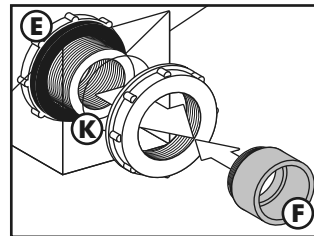

Unscrew the nut from the 2" Bulkhead (E). Place the bulkhead into the Waste Drain (K) with the gasket on the inside of the tank. While holding the bulkhead in place, thread the nut over the exposed threads until snug. Thread the 2" Male Adapter (F) into the 2" Bulkhead (E). Hand-tighten only.

STEP 6: Place Settling Chamber & Connect Plumbing

After the concrete has hardened, place the settling chamber on the footer. With a spirit level, check that the tank is level. If needed, remove excess concrete from the base to allow the tank to set level.

Now that the tank is in place, you can begin connecting the plumbing to and from the pond. Using PVC Pipe and Cement, attach a 4" Gate Valve onto the 4" Female Adapter (D) located at the Inlet (J). Connect and glue the piping from the pond to the 4" Gate Valve.

Glue the 2" PVC Pipe (H) into the 2" Male Adapter (F) located on the Drain (K). Glue the 2" Drain Valve (G) onto the Pipe (H). Attach the Drain Valve (G) to a main drain line, if applicable.

The Outlet (L) can be plumbed to a gravity-fed biological filter or an external centrifugal pump. Follow the equipment manufacturer's installation instructions for proper usage.

STEP 7: Test for leaks

Fill your pond and allow the settling chamber to fill with water. Inspect all fittings and joints for leaks.

Your Cyclone I Vortex is now installed!

Maintenance

The Cyclone I Vortex will help remove a significant amount of waste from your pond, reducing the overall amount of maintenance required. Every 1-2 weeks (or as needed), clean the settling chamber like so:

- 1) Turn off pump & shut 4" gate valve.
- 2) Open the drain valve and allow muck to exit settling chamber.
- 3) Close drain valve, open 4" gate valve & turn on pump.

Frequently Asked Questions

What kind of pump should I use? Any quality, external centrifugal pump rated between 3,000-4,000 GPH is adequate. Choose the most efficient pump you can afford; it will save you money and help protect the environment. Your pond dealer can help you decide which pump to use.

My settling chamber overflows. Why? You have located your settling chamber too low in relation to the pond water level, or the pond water level is elevated due to rainfall or other factors. Raise the settling chamber or lower the water level, and consider installing an overflow to maintain a consistent water level.

My pump is sucking air. Why? There are many things that can cause your pump to suck air:

#1: Water level is too low. Check that your pond is filled with enough water to allow proper operation. If the pond water level is correct, lower the settling chamber until the water level is approximately 1" below the top lip.

#2: Intake line is restricted/Pump is too strong. If the intake line from the pond is too long, too complex or too narrow, the pond will not supply the settling chamber with the proper amount of flow. If the pump is pulling more water than what the unit is rated for, it may begin to suck air. Reduce the flow rate or install an additional feed line to the unit.

#3: Too much outlet plumbing. The settling chamber will not receive an inflow until water is pumping back into the pond. If you have a large amount of piping, it may take a great deal of water to fill it. This will drop the water level in the settling chamber and force the pump to suck air. Install a check valve on the outlet of your pump and prime all plumbing before beginning operation.

A lot of debris is getting past my settling chamber. How can I trap more debris? Your Cyclone Vortex is designed to separate solid matter using centripetal force. As the water spins in the chamber, solids are forced to the outside of the tank. This separates solids based on density, not size. Because of this, the settling chamber is more likely to remove heavy materials like leaves and fish wastes. Light debris like algae and plant matter are more difficult to remove as they have a tendency to float as they decompose.

If you have a valve installed on the output of your pump, you can try adjusting your flow up or down to change the water velocity in the settling chamber. As a rule, higher velocities are preferred – but if the water velocity is too high it will stir up too much debris and negatively impact solids removal. Experiment until you find a flow that works with your particular situation.

How many fish can I keep in my pond? As a rule, keeping less fish is better. Keeping too many fish in your pond can overwhelm your filter, resulting in poor water quality and increased maintenance. Poor water quality will stunt the growth

of your fish and promote harmful diseases. Patio Ponds recommends keeping no more than one adult koi (or ten adult goldfish) per 300-500 gallons. Keeping your stocking levels at or below these levels is strongly recommended.

How much food should I feed my fish? Feed your fish what they can consume in about 1-2 minutes, two to three times daily during the spring and summer. Feeding too much food is wasteful; the fish won't get any extra nutrition and the water quality will suffer as result.

How often should I change the water in my pond? When the pond is properly stocked and there is an adequate amount of rainfall, you should only need to change 25-30% of the pond 2-3 times a season. To conserve water, use the old pond water to water your lawn and garden. Always use a dechlorinator that removes chlorine and chloramine, and remember: topping off for evaporation doesn't count as a water change!

Should I drain all the water to clean out my pond? Although recommended by some, Patio Ponds does not advocate draining and scrubbing the pond at any time. This process is time consuming, wasteful and harmful to the pond environment. A pond grows and becomes more stable over time; completely draining the pond prevents it from maturing. This only leads to more problems in the long run.

Furthermore, your Cyclone Vortex is designed to continuously remove solid wastes that accumulate on the bottom of the pond. This dramatically reduces maintenance and allows your pond to mature faster.

Do I need a UV Clarifier? In most cases, a UV Clarifier is not needed to maintain clear water. If you live in a hot climate, or simply wish to shorten the duration of spring algae blooms, a UV Clarifier may be helpful. Stocking sensibly and avoiding overfeeding will help reduce the need for a UV Clarifier.

Should I keep rocks in the bottom of my pond? Even though it may look aesthetically pleasing at first, placing rocks on the bottom of the pond quickly creates problems. Rocks trap wastes that normally would be removed by the filter. As these wastes rot, they promote algae and disease. These rocks cannot be cleaned easily, even if the pond is drained completely. The pond will be coated with a layer of green after a few seasons regardless, so save yourself the trouble and skip the rocks.

Additional questions? Call or write Patio Ponds today:

Patio Ponds Ltd.
2909 Urbana Pike
Ijamsville, MD 21754

Office phone: 301-874-8440
Office hours: Tue-Fri 10 AM - 5 PM Eastern